



Function

The NOVABOX range, model 300, covers the following hydraulic functions:

- Transfer of energy from a biomass generator
- Energy exchange between the generator and the heating circuit
- Hydraulic separation between the generator and the heating circuit
- Management of the integration circuit for a domestic hot water storage tank
- Auxiliary system functions

The module complies with the provisions of the ISPESL Circular dated 18/09/2006

Primary hydraulic circuit

Max flow rate	2000 l/h
Max temperature	95°C continuous - 110°C peak
Max pressure	6 bar
Residual head at 1000 l/h	6.5 m.w.c.
Fluid	Water - Water + Glycol max 30%
Anti-condensation valve setting	/

Materials

Pipes	Copper
Circulators	Cast iron
Components	Brass / CW617N

Heating hydraulic circuit

Max flow rate	1700 l/h
Max temperature	95°C continuous 110°C peak
Max pressure	6 bar
Non-return valve op. pressure	$\Delta P: 2 \text{ kPa}$ (200 approx.)
Residual head at 1000 l/h	5.4 m.w.c.
Fluid	Water - Water + Glycol max 30%

Dimensions

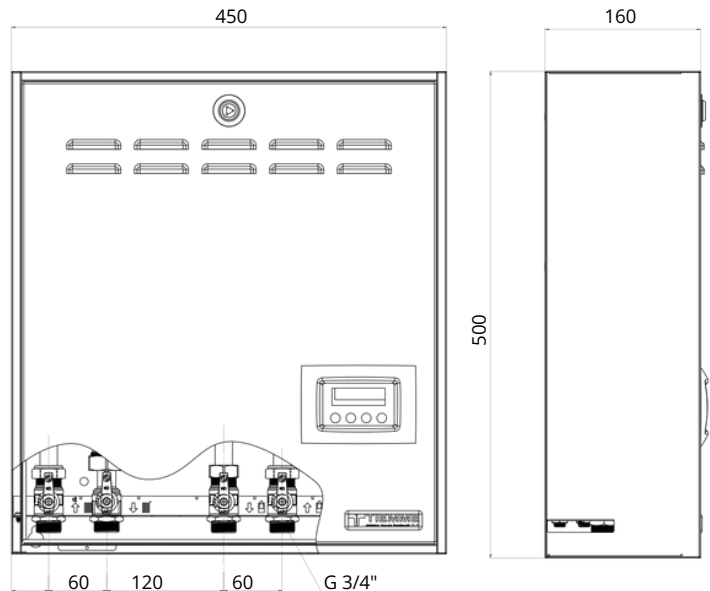

Electrical and mechanical characteristics

Power supply voltage	230V / 50 Hz
Max electrical consumption	Max 110 W
IP protection rating	IPX0D
Control unit setting	CFG 50
Domestic plate heat exchanger	40 plates -35 kW
Connections	3/4" M
Center-to-center distance	60 mm
External dimensions	450x500x160 mm
Weight	15,0 kg

Composition

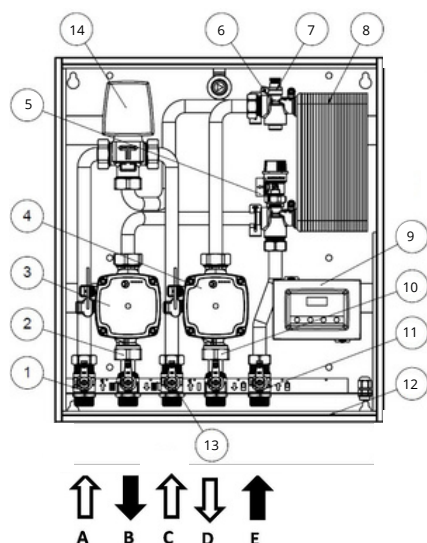

- 1) System return valve with non-return
- 2) System and DHW coil supply valve
- 3) System supply circulation pump
- 4) Generator return circulation pump
- 5) System safety valve
- 6) System air vent
- 7) Generator air vent
- 8) Plate heat exchanger
- 9) Control unit
- 10) Generator return valve
- 11) Generator supply valve
- 12) Metal box
- 13) DHW coil return valve with non-return
- 14) Diverter valve

- A) Heating return
- B) Heating flow
- C) Serpentine return
- D) Return to generator
- E) Generator flow

Accessories



CONTROL UNIT

Control unit TC100
(Cod. CF105175)



CIRCULATOR UPM3

CIRCULATOR UPM3 HYBRID
(Cod. R0105078)



AIR VENT VALVE 1/4"

Air vent valve
(Cod. CF105001)



PROBE WELL

Probe well 6mm
(Cod. CF405111)



NTC PROBE

Ntc probe 6mm - ntc 10k@25°
(Cod. R3705089)



PLATE HEAT EXCHANGER

Plate heat exchanger swep E5ASH - 20 plates (COD. R0105410)
Plate heat exchanger swep E5ASH - 40 plates (COD. R0105409)



ESBE VZC 162

Zone valve without cable
(CF105190)

Certifications

- Product compliant with:
- EN 16297-2 / EN 16297-3:2012 ErPReady
 - PED Directive - 2014/68/EU

