



## Function

The new range of Fresh Water Station products is the perfect solution for the instant production of Domestic Hot Water. The innovative control algorithm allows the FWS to be paired with inertial storage tanks powered by heat pumps or condensing boilers. High performance, energy efficiency, compact dimensions, and easy maintenance are the common features of the NOVAHYDRO platform.

## Technical data

Dimensions with cover	600 x 360 x 170
Primary connections	1" M
Sanitary connections	3/4" M
Connection center distance	80
Weight	17 Kg
Plate exchangers	AISI 316L stainless steel
Exchanger insulation	Yes
Free space above	200
Free space below	300
Free space around	100
Free space in front	50
Installation type	Wall-hung / on storage tank

## Primary circuit

Max pressure	10
Max temperature	90
Max differential pressure	/
Max flow rate	2500
Fluid	Water/Water+Glycol max 30%
Circulator	Moons MPC PWM
Max head of circulator	7,5
PICV control valve	/
Pressure sensor	Yes
Pressure sensor calibration	0 - 4

## Electrical characteristics

Power supply	230 ± 10% [V] - 50/60 [Hz]
Maximum electrical consumption	80
IP protection class	IPX0D
Temperature sensors	PT1000
Protection fuse	2A slow blow 250V

## Sanitary water circuit

Working pressure	0,5 ÷ 10
Flowmeter operating range	VTY 20
Minimum flow rate flowmeter ON	1 ÷ 60
Pressure drop	0,6
Performance at different ΔT	See specific table
Domestic hot water regulation	See specific table
Range	30 ÷ 85
Factory setting for domestic hot	45
Water	Yes
Preheating function	Yes
Legionella prevention function	Yes
Recirculation function	Wilco Star Z-NOVA
Safety valve	Yes
Safety valve calibration	8
Safety valve discharge	3/4" M
"CASCATA" connection	Yes
Plate heat exchanger	ZILMET ZB 350
Number of plates	36
Heat exchanger cleaning system	Yes

## Dimensions

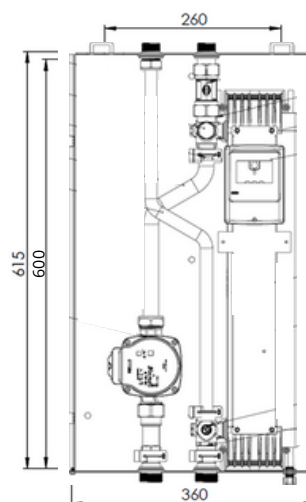

**Indicative diagrams**

- 1 - FWS S - M
- 2 - Thermal storage
- 3 - Heat generator
- 4 - System hydraulics
- 5 - Domestic water network
- 6 - DHW draw-off point

**HEAT PUMP GENERATOR DIAGRAM**

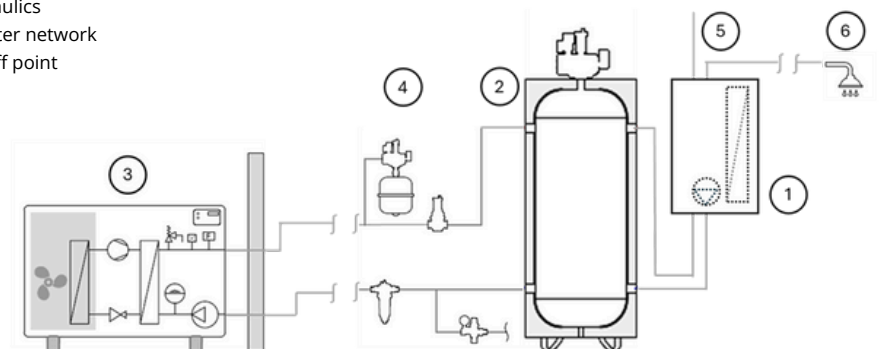

- 1 - FWS S - M
- 2 - Thermal storage
- 3 - Heat generator
- 4 - System hydraulics
- 5 - Domestic water network
- 6 - DHW draw-off point

**CONDENSING BOILER GENERATOR DIAGRAM**

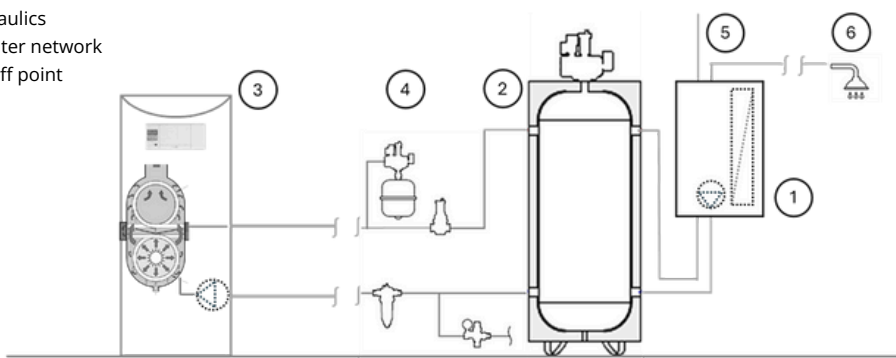

## Hydraulic diagram

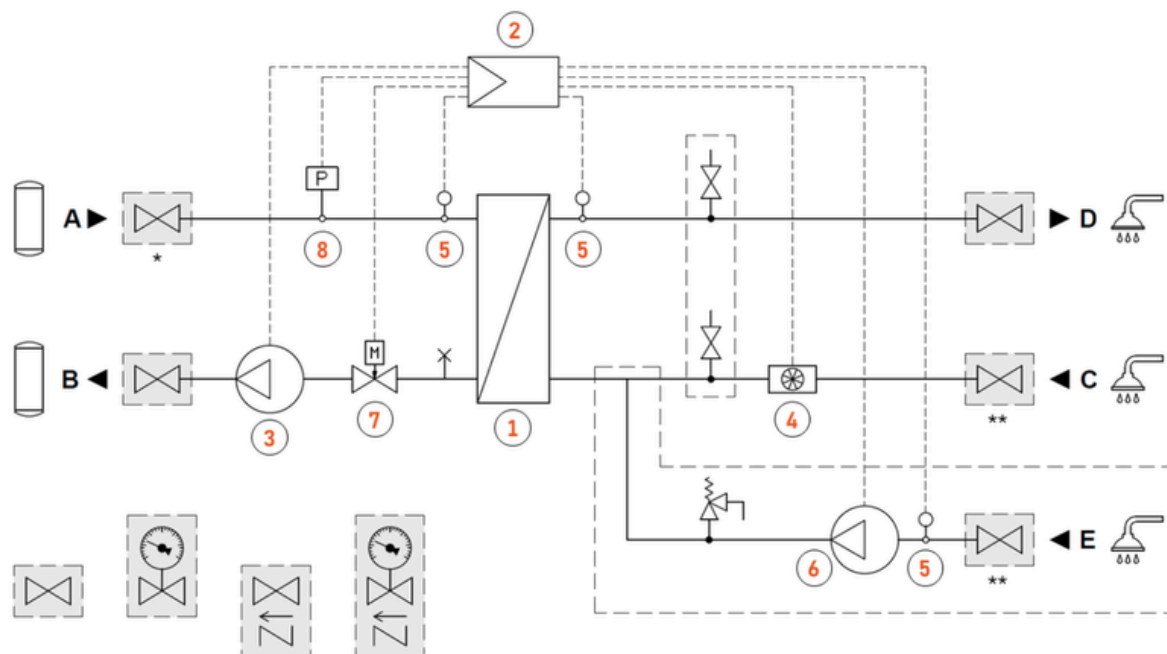

- 1 - 36-plate heat exchanger
- 2 - Control unit
- 3 - Primary pump circuit
- 4 - Flow meter 1-60 L/min
- 5 - Temperature sensor
- 6 - Pump circulation function
- 7 - Primary modulating flow valve
- 8 - Pressure sensor