



Function

The NOVACdC 12000 module is capable of managing a two-way heating circuit (Mod. 121000) or a three-way circuit (Mod. 12110). It allows for the metering of user consumption for both heating and domestic hot/cold water. The alternative to an individual heating system is a centralized system with individual heat metering and autonomous temperature control. This system combines the advantages of both centralized and individual heating systems, thanks to individual meters—each user pays only for the heat they have actually consumed.

Technical data

Max pressure	10 bar
Max working temperature	95°C
Min working temperature 1)	5°C
Liquid	Water – Water + Glycol max 30%
Heating circuit connections	1" F
Center distance	130 mm
Heating pressure losses 2) 3)	Specific graphs
DHW circuit connections	3/4" F
Center distance	80 mm
DHW pressure losses 4) 5)	Specific graphs
Zone valve power supply 6)	230 V – 50 Hz
Heat meter provision	130 mm – 1" M
DHW meter provision	110 mm – 3/4" M
External dimensions	568 x 538 x 125 mm
Box material	White painted metal
Cover with lock and key	Yes
Filter	Yes

- 1)** In case of cooling, provide adequate insulation
- 2)** Value without heat meter
- 3)** Specific graphs for "Heating pressure losses"
- 4)** Value without domestic water meter
- 5)** Specific graphs for "DHW pressure losses"
- 6)** 24 V version available on request

Materials

Pipes	Copper
Casing	FE painted
Components	Brass / CW617N

Pressure losses

HEATING PRESSURE DROPS

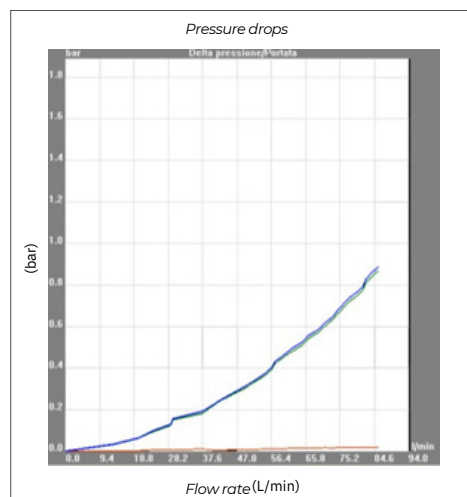

Composition

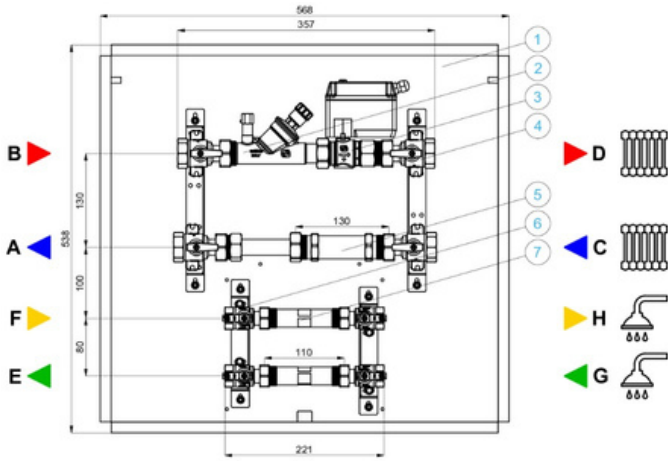

- 1) Metal box
 - 2) Flow regulator with filter
 - 3) Two-way zone valve
 - 4) Ball valve 1" F
 - 5) Heat meter (optional)
 - 6) Ball valve 3/4" F
 - 7) Domestic water meter (optional)
- A) HeatGenerator Return
 - B) HeatGenerator Supply
 - C) Heating Return
 - D) Heating Supply
 - E) HeatGenerator Return
 - F) HeatGenerator Supply
 - G) Sanitary Return
 - H) Sanitary Supply

Hydraulic functional diagram

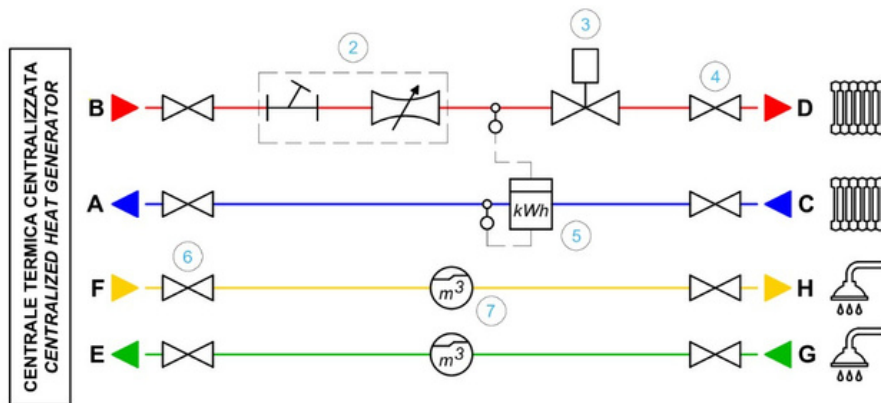

Certifications

Product compliant with:
- EN 16297-2 / EN 16297-3:2012 ErPReady
- PED Directive – 2014/68/EU

